

0001/M9R39VB

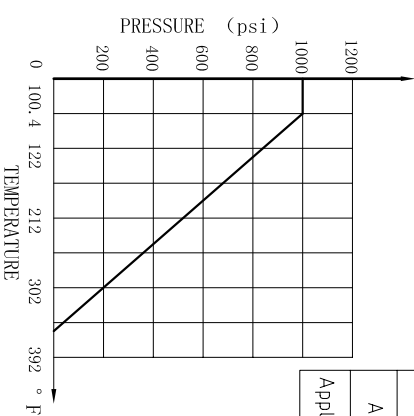
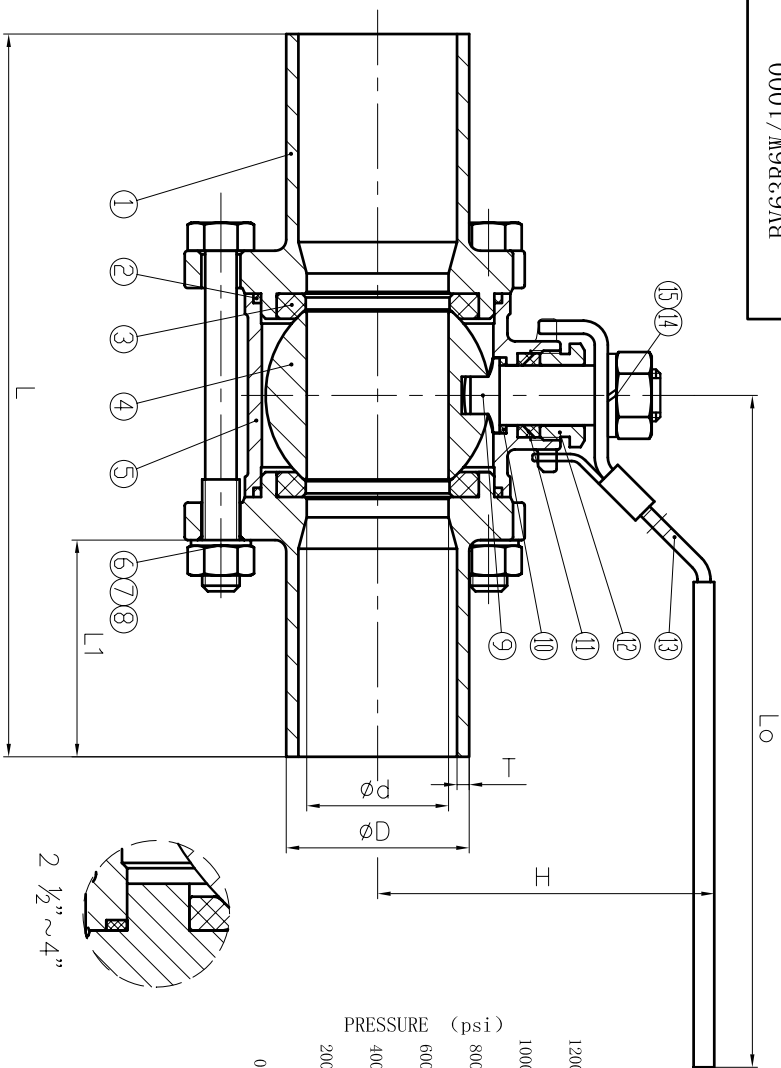

NOTE:
 1. Design and Manufacture for valve according to ASME B16.34.
 2. Inspection and Test for valve according to API 598.

Nominal pressure			1000Psi		
Test pressure	Shell test	10.4	Test medium	Water	Test temperature
	Seal test	7.6		temperature	Normal temperature
	Gas seal test	0.6	Air		
Applicable medium			Water, Oil, Gas		
Applicable temperature			-20~356°F		

NPS	L	L1	d	D	T	Lo	H	Weight (lb)
1/2"	5.933	2.165	0.591	0.854	0.083	4.134	2.126	1.411
3/4"	6.130	2.224	0.768	1.071	0.083	4.724	2.579	1.786
1"	7.331	2.677	0.984	1.339	0.110	5.512	2.835	2.535
1 1/4"	7.701	2.598	1.260	1.681	0.110	5.906	3.189	4.575
1 1/2"	9.118	3.150	1.496	1.913	0.110	6.693	3.780	5.401
2"	9.583	3.031	1.929	2.382	0.110	7.283	4.134	7.716
2 1/2"	11.425	3.720	2.520	3.004	0.118	8.661	4.724	-
3"	11.898	3.602	3.031	3.508	0.118	10.623	5.295	-
4"	12.843	3.563	3.898	4.500	0.118	12.402	6.181	-

15	NUT	1	A194 8
14	SPRING WASHER	1	304
13	HANDLE	1	STAINLESS STEEL
12	GLAND	1	304
11	PACKING	1	RPTFE
10	STEM WASHER	1	RPTFE
9	STEM	1	A276 316
8	NUT	-	A194 8
7	SPRING WASHER	-	304
6	HEXAGON HEAD BOLT	-	A193 B8
5	BODY	1	A351 CF8M
4	BALL	1	SS316
3	SEAT	2	RPTFE
2	GASKET	2	RPTFE
1	BONNET	2	A351 CF8M
NO.	DESCRIPTION	QTY	MATERIAL
MARK		SCALE	
BEFORE MODIFIED	AFTER MODIFIED		
DRAWN	APP.		
DATE	DATE		
CHK.			
ANIX VALVE CO., LTD		3PC Ball Valve	
1000PSI, Extended Weld		BV63R6W/1000	